



Wolf Safety Lamp Company

WOLF AIRTURBO LAMPS

Nos. A-0444 and A-0445

OPERATION AND MAINTENANCE INSTRUCTIONS

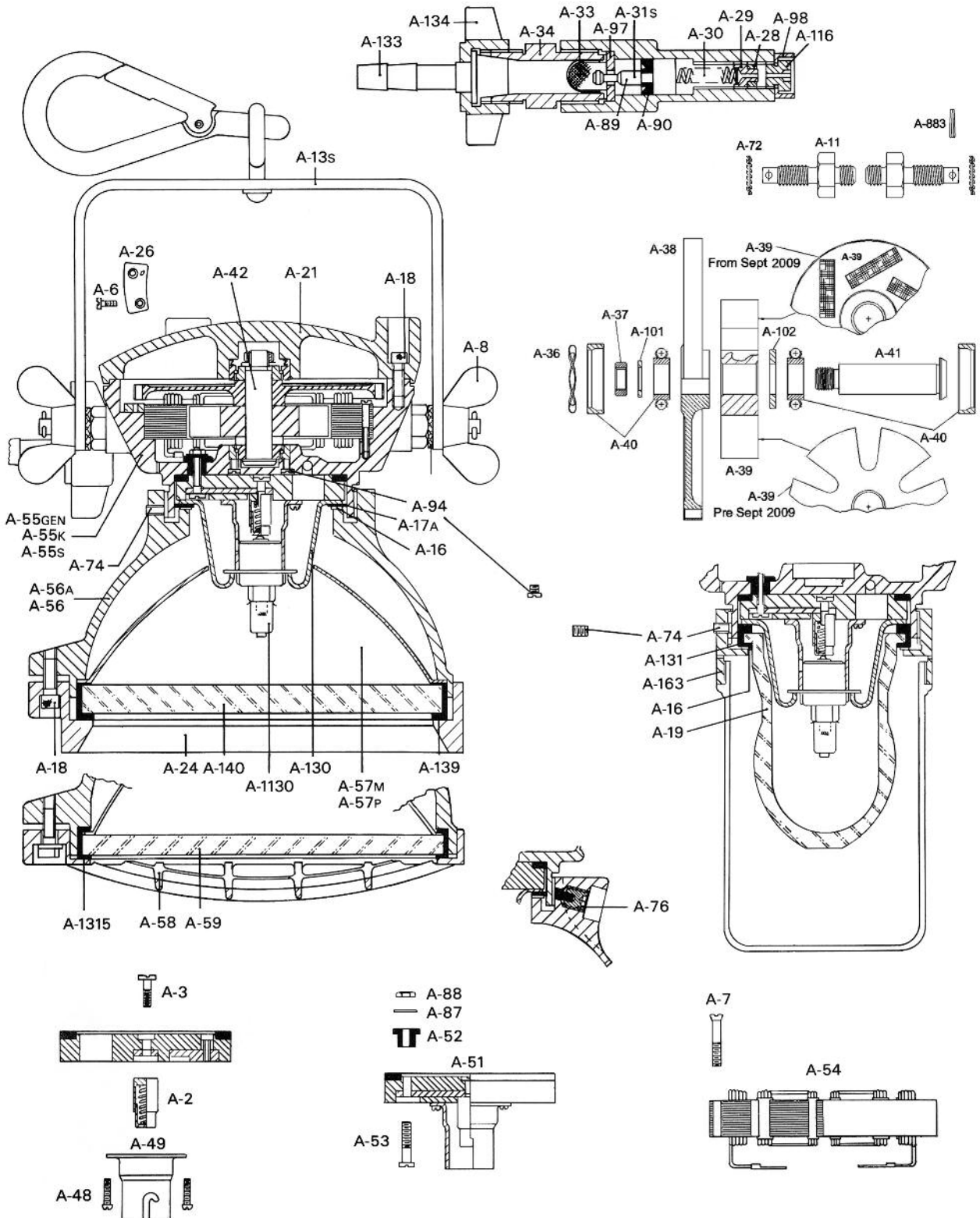

EXTERNAL FEATURES MAY CHANGE WITHOUT NOTICE

Wolf Airturbo Lamps Nos. A-0444 and A-0445

Operation and Maintenance Instructions

Introduction

The Wolf 'Airturbos' are 55 Watt Tungsten Halogen compressed air operated safety lamps. No. A-0444 is fitted with a 'Bay Light' head for general illumination. A-0445 has a Reflector Head with either a Matt or Polished Reflector providing wide angle or concentrated levels of lighting. They are certified by BASEEFA (Ex 78209X) to Special Protection – SFA 3009 for safe use in Zone 1 and Zone 2 Hazardous Areas, with a Temperature Classification – T6. This covers safe use in up to T6 range of explosive gases and vapours as listed in 'Code of Practice BS 5345 Part 1: 1989.'

Quality Assurance Standards to ISO 9000:2000 apply to manufacture, assembly and final inspection and testing of all lamp units.

Operating Instructions

The operating pressure of the Wolf 'Airturbo' is between 4.5 and 8 bar.

The pressure regulator of the lamp unit compensates for the above range of input pressures as well as fluctuations in airline pressures.

WARNING: DIRT OR MOISTURE FROM UNFILTERED AIR WILL DEPOSIT ON THE INSIDE OF THE GLASS DISC OR BALL GLASS REDUCING LIGHT OUTPUT. THE REFLECTOR HEAD AND BALL GLASS OF THE LAMPS ARE PRESSURISED ENCLOSURES. DO NOT COVER OR OBSCURE LIGHT TRANSMITTING PARTS.

Maintenance of Wolf 'Airturbos'

The maintenance and repair of Wolf 'Airturbo' lamps should only be undertaken by trained or qualified electrical fitters or engineers. Lamps should be cleaned and tested every three months if in regular use, and every six months where use is less frequent.

As a guide, reference may be made to:

BSEN 60079-14:1997, IEC 60079-14:1996 Electrical Apparatus for Explosive Gas Atmospheres. Electrical Installations in Hazardous Areas. BSEN 60079-17:1997. IEC 60079-17:1996 Inspection and Maintenance of Electrical Installations in Hazardous Areas. The use of incorrect spare parts and the improper fitting of spare parts will invalidate certification and the Manufacturer's Guarantee. Full details of maintenance and repair procedures follow. If in doubt contact the Company.

Bulb Changing

The 12 Volt 55 Watt Tungsten Halogen Bulb should be handled with care, if it becomes misted or dirty it should be cleaned with a soft cloth, moistened with methylated spirit.

A-0445:

To gain access to the Bulb, the Reflector Head Assembly A-56A is unlocked by releasing Lockscrew A-74, which allows it to be unscrewed from the Generator Housing. Remove together the Metal Washer A-16, Rubber Washer A17A and the Air Inlet Reflector A-130. Fit the Spare Bulb in the Bulbholder A-49 and replace other parts in the reverse order: these parts will be clamped in position when the reflector head is screwed back onto the Generator Housing. Ensure Lockscrew A-74 is refastened. Care should be taken when fitting the Bulb to ensure that the flange of the Air Inlet Reflector does not make contact with the Generator Housing. This could only happen with lamps made before June 1971. (The date of manufacture

is on the Approval plate.) If, with the bulb in place, there is contact, a new air inlet reflector should be fitted.

A-0444:

Lockscrew Ring/Guard A-163 for Ball Glass is removed from the Generator Housing and the Bulb replaced in much the same manner except that Rubber Washer A-17A is not fitted or required in this instance.

When replacing the Reflector Head/Bay Light Head, screw down with only sufficient torque to seal the pressurised enclosure. The seals are internal by way of A-131 Grooved Rubber Washer for Ball Glass or Rubber Washer A-17A for Reflector Head. Ensure Metal Washer A-16 is uppermost on the Rubber Washer before re-fitting either type of Head. In both cases refasten Lockscrew A-74.

Replacing/Cleaning Glass Disc A-0445

THE REFLECTOR HEAD OF THE WOLF 'AIRTURBO' LAMP IS A PRESSURISED ENCLOSURE.

The lens ring A-24 retains the glass disc A-140 (15mm). To remove unfasten the four high tensile Stainless Steel Fastening Screws A-18. The Glass Disc is mounted inside the Grooved Rubber Washer A-139. The reflector sits in the reflector head. These items can be removed for cleaning/replacement.

The Grooved Rubber Washer in particular, should be inspected for any damage, as this provides a pressurised seal on both faces of the Reflector Head enclosure.

When re-assembling ensure that this Washer is evenly fitted on both faces of the Glass Disc. Place reflector in reflector head before the lens with seal.

Refastening of this assembly into the Reflector Head must follow normal good practice in fastening down a flanged joint; the 4 Screws A-18 should be fastened down opposite and evenly, only sufficiently to make an airtight seal.

INCORRECT FASTENING OF THESE SCREWS CAN CAUSE:

- The toughened Glass Disc to shatter.
- The Grooved Rubber seal to become damaged.
- Weakening of the Fastening Screws.
- Stripping of the threads in the Reflector Head.

NOTE: Lockwashers are no longer fitted with Fastening Screws A-18.

Replacing/Cleaning Ball Glass A-0444

After cleaning/replacement as necessary, the Ball Glass A-19 together with Grooved Rubber Washer for Ball Glass A-131 is fitted in the Generator Housing recess first, followed by Metal Washer A-16 then the Lockscrew Ring/Guard A-163 is screwed firmly down and locked as previously described.

Lubrication

The magneto type Bearings require a medium grade non-emulsifying grease, which should be applied after 1000 hours running time. Grease nipples are no longer fitted to the Generator Housing and Cover as this encouraged over greasing. Access to the Bearings requires removing just the three Fastening Screws A-18 in the Housing Cover A-21. Should the Housing Cover resist removal, then the edge of the rim should be tapped with a mallet at several points to free the joint.

The Rotor Complete A-42 can then be lifted out of the open Generator Housing. This may require either a pair of pliers or the aid of Key A-146 on Nut for Rotor Shaft.

A smear of grease can then be applied to the caged Bearings on each end of the Rotor Shaft and in the races situated in the Generator Housing and Housing Cover respectively. Before replacing the Rotor Assembly make sure that no small ferrous objects have been attracted to the Magnet. Care must be taken when replacing the Assembly to avoid fingers becoming trapped between the Turbine Wheel and the Generator Housing as the Magnet is attracted to the Stator.

Replacing Bearings

Remove Nut for Rotor Shaft A-37 on the Rotor Assembly, Washer A-101, first Bearing A-40, Turbine Wheel A-38, Magnet A-39, and finally second Bearing A-40 from the Rotor Shaft A-41. These parts should be cleaned and replaced in reverse order together with new bearings.

Underneath the outer race of the Bearing in Housing Cover A-21 is fitted a Waved Spring Washer A-36. This ensures the correct loading of the bearings. It is important to check that the Waved Spring Washer is in good condition before fitting a new outer Bearing race. The other outer Bearing race is a tight fit in the Generator Housing:

To replace this Bearing race, first remove the Lamp Head and then the Rotor Complete A-42 from the Generator Housing. Unscrew the two Nuts for Stator Terminal A-88 and push through the two Connecting Screws A-53. These screws are insulated and sealed by Insulating Bushes A-52, and carry the power from the Stator Winding A-54. If removed, it is essential to ensure that the Insulating Bushes are in good condition, because as well as providing electrical insulation, they also provide a pressure seal between the Reflector Head and the Generator Housing.

The Contact Plate A-51 can then be extracted and the two Screws for Bearing Race A-94 can be removed so that Forked Tool A-147 can be inserted through the holes and used for tapping out the Bearing Race. Clean the bearing recess before fitting a new Bearing Race in position.

The Bearings and races should be lubricated with a smear of grease. When replacing the Housing Cover A-21, spring lift will indicate that the Bearings are properly loaded.

Magnet

The A-39 Magnet has a long life but should be kept clean and free from iron filings and ferrous objects. Magnet style changed Sept 2009, from then on magnet will be marked A-39. The magnet should be a light sliding fit onto the rotor shaft and should never be tapped or hit with a hammer as this can affect the magnetism and may cause sharp pieces to break off. Avoid close proximity of any large ferrous objects.

Air Regulator Assembly

All the Air Regulator parts are fastened in position by Connecting Piece A-34 with Air Filter Sieve A-33 and should not be disturbed unless the Regulator ceases to function correctly. While ever fastened, the Connecting Piece also maintains the alignment of the Air Regulating Plate A-97. Removal of these parts gives access to Pressure Regulating Piston complete A-31s and Spring for Piston A-30.

These parts are withdrawn from the front of the piston chamber and should be cleaned and examined for wear and damage and replaced as necessary. In particular the lip of Rubber Seal for Piston A-90 should be checked for damage or wear.

Before re-assembly of the Piston parts, the Regulating Screw A-29 and Lock Nut A-28 must be removed from the other end of the piston chamber. Hexagon Lock Key A-171 will be needed to remove Lockscrew A-116 and Pair of Pressure Regulating Keys A-68 to remove Regulating Screw and Lock Nut.

The Regulating Screw A-29 and Lock Nut A-28 should then be loosely fitted just inside the end of the piston chamber, ready for resetting the pressure regulator and hence the generator electrical output.

Setting Generator Voltage Output

Airturbo Setting and Testing Device A-200 will be required for correct setting of the Generator output, adjusted by re-setting the Air Regulator. The Setting and Testing Device is fitted on the Generator in place of the Head and all other associated parts, including the Bulb, fastened and sealed with Screwed Handle A-189. The Bulb is fitted and fastened by means of a clip in the Bulbholder on top of the Setting and Testing Device and Voltmeter connections are made to the two terminals.

Couple up and turn on a CLEAN and DRY supply of compressed air to the Lamp, checking first that no air is escaping past the Pressure Regulating Piston by sealing the exposed hole with the thumb, an escape will be indicated by an increase in Turbine speed and Voltage reading. In such circumstances the Rubber Seal for Piston A-90 should be replaced as above, with a smear of grease to assist assembly.

Using the Pair of Pressure Regulating Keys A-68, screw in Regulating Screw A-29 to increase voltage output or screw out to decrease Voltage output. When the Voltage output is steady at between 11.5 and 12.0 Volts, turn the air supply off and on several times, allowing the Turbine to achieve maximum speed each time and make any minor adjustments if necessary. Leave the Lamp running for 15 minutes before making any final adjustments to the regulating screw. The setting can now be locked with Lock Nut A-28 using the outer sleeve of the Keys and finally, replace Lockscrew for Piston Chamber A-116 together with Collar A-98 to secure the setting.

Use of Wolf 'Airturbo' in Hazardous Areas

The introduction details the Hazardous Area Zones of Use and the Temperature Classification of the 'Airturbo' but users are advised to consult BSEN 60079-14:1997 IEC 60079-14:1996 Electrical Apparatus for Explosive Gas Atmospheres. Electrical Installations in Hazardous Areas, before operating in a Hazardous Area.

Conditions of Certification are that clean, dry compressed air must be used to power the lamps through anti-static air hose of resistances between connection, 10^8 ohms maximum and 10^4 ohms minimum to NCB Specification P182 or BS 2050.

These lamps are not solidly earthed and when used in Tankers the precautions against the hazards of static electricity in cargo tanks, as set out in the International Chamber of Shipping 'Tanker Safety Act (Petroleum)' as amended, or 'The Oil Tanker and Terminal Safety Guide', 1977 edition, should be observed.

Major changes in design are permitted as Variations of Approvals but may otherwise be made without prior notice.

Wolf Airturbo Lamps Nos. A-0444 and A-0445

Parts List

Type A-0444		Type A-0445
Part No.	Description	Part No.
A-2	Contact Plunger	A-2
A-3	Screw for Contact Plunger	A-3
A-6	Screw for Air Inlet Plate (2)	A-6
A-7	Screw for Stator (3)	A-7
A-8	Wing Nut (2)	A-8
A-11	Bridle Bolt (2)	A-11
A-13s	Bridle with Safety Hook	A-13s
A-16	Metal Washer	A-16
	Rubber Washer	A-17A
A-18 (3)	Stainless Steel Fastening Screws	A-18 (7)
A-19	Ball Glass	
A-21	Housing Cover	A-21
	Lens Ring	A-24
A-26	Air Inlet Plate	A-26
A-28	Lock Nut for Regulating Screw	A-28
A-29	Regulating Screw	A-29
A-30	Spring for Piston (Gold-Passivated)	A-30
A-31s	Piston Complete	A-31s
A-33	Air Filter Sieve	A-33
A-34	Connecting Piece	A-34
A-36	Waved Spring Washer for Bearing (1)	A-36
A-37	Nut for Rotor Shaft	A-37
A-38	Turbine Wheel	A-38
A-39	Magnet	A-39
A-40	Ball Bearing with Race (2)	A-40
A-41	Rotor Shaft	A-41
A-42	Rotor Complete	A-42
A-48	Long Screw for Bulbholder	A-48
A-49	Bulbholder	A-49
A-51	Contact Plate complete	A-51
A-52	Insulating Bush (2)	A-52
A-53	Connecting Screw (2)	A-53
A-54	Stator Winding	A-54
A-55GEN	Complete Airturbo Generator	A-55GEN
A-55K	Generator Housing Complete	A-55K
A-55s	Generator Housing only	A-55s
	Reflector Head	A-56
	Reflector Head Assembly	A-56A
	Matt Reflector	A-57M
	Polished Reflector	A-57P
A-72	Lock Washer for Bridle (2)	A-72
A-74	Lock Screw for Rfl-Hd./Guard	A-74
A-87	Washer for Connecting Screw (2)	A-87
A-88	Nut for Connecting Screw (2)	A-88
A-89	Pressure Regulating Piston only	A-89
A-90	Rubber Seal for Piston	A-90
A-94	Screw for Bearing Race in A-55s (2)	A-94
A-97	Air Regulating Plate	A-97
A-98	Collar for Lockscrew-Piston Chamber	A-98

Type A-0444		Type A-0445
Part No.	Description	Part No.
A-101	Washer for Rotor Shaft Nut	A-101
A-102	Rotor Spacer	A-102
A-116	Lock Screw for Piston Chamber	A-116
A-130	Air Inlet Reflector	A-130
A-131	Grooved Rubber Washer for Ball Glass	A-131
A-133	Connecting Tube	A-133
A-134	Overthrow Nut	A-134
	Grooved Rubber Washer 15mm	A-139
	Glass Disc 15mm (toughened)	A-140
A-163	Lockscrew Ring/Guard	
A-883	Split ring for bridle bolt(2)	A-883
A-1130	Bulb 12v 55w Tungsten Halogen	A-1130

Tools and Accessories for use with Wolf Airturbo Lamps

Tools

A-68	Pair of Pressure Regulating Keys	A-68
A-146	Key for Nut No. A-37	A-146
A-147	Forked tool for removing Bearing Race	A-147
A-170	Hexagon Key for A-18s (3/16" A/F)	A-170
A-171	Hexagon Key for A-74 (2.5mm A/F)	A-171

Accessories

A-178	Lubricant 400 gram tube	A-178
A-179	Antistatic Hose 1/2" bore 18.3m (60')	A-179
A-180	Antistatic Hose 1/2" bore 36.6m (120')	A-180
A-181	Stainless Steel Hose Clips	A-181
A-183	Portable A.C. Voltmeter	A-183
A-184	Filter/Automatic Drain Unit (6 Lamps)	A-184
A-186	Ultra High Efficiency, Two Stage Filter/ Automatic Drain Unit (6 Lamps)	A-186
A-189	Screwed handle – Set & Test Device	A-189
A-200	Setting & Testing Device complete	A-200
A-300	Folding Tripod Stand	A-300

Pre-December 1986 parts still available for Wolf Airturbo Lamp No. A-0445 (0445/U/M)

Guard Ring for 10mm Glass Disc	A-58
Glass Disc 10mm (toughened)	A-59
Nylon Lock Pellett	A-75
Lock Screw with No. 75	A-76
Grease Nipple	A-79
Grooved Rubber Washer 10mm	A-1315

Substitute/Obsolete (OBS) Parts

No. 4	Washer for Bridle Bolt No. 10	OBS
No. 10	Bridle Bolt	A-11
No. 20s	Stainless Steel Fastening Screws	A-18
No. 27	Lockscrew for Piston Chamber	A-116
No. 35s	Housing Cover	A-21
No. 65	Spring Washer for No. 20s	OBS

WOLF SAFETY LAMP COMPANY

Saxon Road Works, Sheffield S8 0YA, England

Tel: +44 114 255 1051 Fax: +44 114 255 7988

E-mail: info@wolf-safety.co.uk Website: www.wolf-safety.co.uk



Wolf Safety Lamp Company